

The data to be read in conjunction with the Hydrogen Thyatron Preamble.

## ABRIDGED DATA

Deuterium-filled, three-gap, high voltage thyatron with ceramic/metal envelope, featuring low jitter, firing time and drift. Suitable for switching high power at high pulse repetition rates or for switching long pulses. A reservoir operating from a separate heater supply is incorporated.

Peak forward anode voltage . . . . .	105	kV max
Peak anode current . . . . .	3.0	kA
Average anode current . . . . .	2.0	A max
Rate of rise of current . . . . .	> 150	kA/ $\mu$ s

## GENERAL

### Electrical

Cathode (connected internally to one end of heater) . . . . .	oxide coated
Cathode heater voltage . . . . .	6.3 + 0.5 - 0.0 V
Cathode heater current . . . . .	22.5 A
Reservoir heater voltage (see note 1) . . . . .	5.0 V
Reservoir heater current . . . . .	7.0 A
Tube heating time (minimum) . . . . .	15 min
Inter-electrode capacitances (approx):	
anode to gradient grid 2 . . . . .	15 to 20 pF
gradient grid 2 to gradient grid 1 . . . . .	15 to 20 pF
gradient grid 1 to grid 2 . . . . .	15 to 20 pF

### Mechanical

Seated height . . . . .	342.9 mm (13.500 inches) max
Clearance required below mounting flange . . . . .	38.1 mm (1.500 inches) min
Overall diameter (mounting flange) . . . . .	111.1 mm (4.375 inches) nom
Net weight . . . . .	4.0 kg (8 <sup>3</sup> / <sub>4</sub> pounds) approx
Mounting position (see note 2) . . . . .	any
Tube connections . . . . .	see outline

<b>Cooling</b> . . . . .	liquid
Liquid . . . . .	oil or coolant immersion

Cooling by oil or coolant immersion is necessary for satisfactory tube operation. Further information is contained in the relevant section of the Preamble.

Envelope temperature:	
ceramic, anode and grids . . . . .	150 °C max
cathode flange and base . . . . .	120 °C max



## MAXIMUM AND MINIMUM RATINGS

### (Absolute values)

These ratings cannot necessarily be used simultaneously, and no individual rating may be exceeded.

	Min	Typical	Max	
<b>Anode (Pulse Modulator Service)</b>				
Peak forward anode voltage	-	-	105	kV
Peak inverse anode voltage (see note 3)	-	-	105	kV
Peak anode current	-	3.0	-	kA
Peak anode current (pulse repetition rate limited to 60 pps max)	-	-	4.0	kA
Average anode current	-	-	2.0	A
Rate of rise of anode current (see notes 4 and 5)	-	10	-	kA/ $\mu$ s
Pulse repetition rate (see note 6)	-	400	-	pps

### Anode (Single-Shot or Crowbar Service, see note 7)

	Min	Max	
DC forward anode voltage	-	80	kV
Peak anode current	-	10	kA
Total conducted charge:			
capacitor discharge	-	0.1	C
crowbar service (see note 8)	-	4.0	C
Repetition frequency	1 pulse per 10s	max	

### Grid 2

Unloaded grid 2 drive pulse voltage (see note 9)	500	2000	V
Grid 2 pulse duration	0.5	-	$\mu$ s
Rate of rise of grid 2 pulse (see note 5)	10	-	kV/ $\mu$ s
Grid 2 pulse delay	0.5	3.0	$\mu$ s
Peak inverse grid 2 voltage	-	450	V
Loaded grid 2 bias voltage	-50	-200	V
Forward impedance of grid 2 drive circuit	50	500	$\Omega$

### Grid 1 - Pulsed

Unloaded grid 1 drive pulse voltage (see note 9)	300	1000	V
Grid 1 pulse duration	2.0	-	$\mu$ s
Rate of rise of grid 1 pulse (see note 5)	1.0	-	kV/ $\mu$ s
Peak inverse grid 1 voltage	-	450	V
Loaded grid 1 bias voltage	-	see note 10	
Peak grid 1 drive current	0.3	1.0	A

### Grid 1 - DC Primed (See note 7)

DC grid 1 unloaded priming voltage	75	150	V
DC grid 1 priming current	75	150	mA

### Cathode

Heater voltage	6.3	6.8	V
Heating time	15	-	min

### Reservoir

Heater voltage (see note 1)	4.5	6.5	V
Heating time	15	-	min

## Environmental

Ambient temperature	-50	+90	$^{\circ}$ C
Altitude	-	3	km
	-	10 000	ft

## CHARACTERISTICS

	Min	Typical	Max	
<b>Critical DC anode voltage for</b>				
conduction (see note 11)	-	5.0	7.0	kV
<b>Anode delay time</b>				
(see notes 11 and 12)	-	0.1	0.25	$\mu$ s
<b>Anode delay time drift</b>				
(see notes 11 and 13)	-	15	50	ns
Time jitter (see note 11)	-	1.0	5.0	ns
Recovery time	-	-	-	see note 6
<b>Cathode heater current</b>				
(at 6.3 V)	20	22.5	25	A
<b>Reservoir heater current</b>				
(at 5.0 V)	6.0	7.0	8.0	A

## NOTES

- The reservoir heater must be decoupled with a suitable capacitor to avoid damage by spike voltages. The recommended reservoir heater voltage is stamped on individual tube envelopes. For maximum rate of rise of current the voltage should be set to the highest value compatible with maintenance of anode hold-off voltage. The reservoir voltage should be stabilised to  $\pm 0.05$  V.
- The tube must be mounted by means of its mounting flange.
- The peak inverse voltage including spike must not exceed 10 kV for the first 125  $\mu$ s after the anode pulse.
- In single-shot or burst mode, this parameter can exceed 150 kA/ $\mu$ s. The ultimate value which can be attained depends to a large extent upon the external circuit.
- This rate of rise refers to that part of the leading edge of the pulse between 25% and 75% of the pulse amplitude.
- Triggered charging techniques are recommended because this thyratron has a long recovery time (100 - 200  $\mu$ s) due to the gradient grid drift space. The amount of time required for recovery is affected by gas pressure, peak current, pulse duration and load mismatch which keeps the thyratron in a conducting state.
- When DC priming is used on grid 1, a negative bias of 100 to 200 V must be applied to grid 2 to ensure anode voltage hold-off. Also the higher grid 1 is pulsed, the larger must the grid 2 negative bias be, to prevent the tube firing on the grid 1 pulse. Grid 1 DC priming is recommended for crowbar service.
- In crowbar service, most of the coulombs are often in the power supply follow-on current, rather than the storage capacitor discharge.
- Measured with respect to cathode. When grid 1 is pulse driven, the last 0.25  $\mu$ s of the top of the grid 1 pulse must overlap the corresponding first 0.25  $\mu$ s of the top of the delayed grid 2 pulse.
- DC negative bias voltages must not be applied to grid 1. When grid 1 is pulse driven, the potential of grid 1 may vary between -10 and +5 V with respect to cathode potential during the period between the completion of recovery and the commencement of the succeeding grid pulse.

11. Typical figures are obtained on test using conditions of minimum grid drive. Improved performance can be expected by increasing grid drive.
12. The time interval between the instant at which the rising unloaded grid 2 pulse reaches 25% of its pulse amplitude and the instant when anode conduction takes place.
13. The drift in delay time over a period from 10 seconds to 10 minutes after reaching full voltage.

## SCHEMATIC DIAGRAM (Modulator Service)

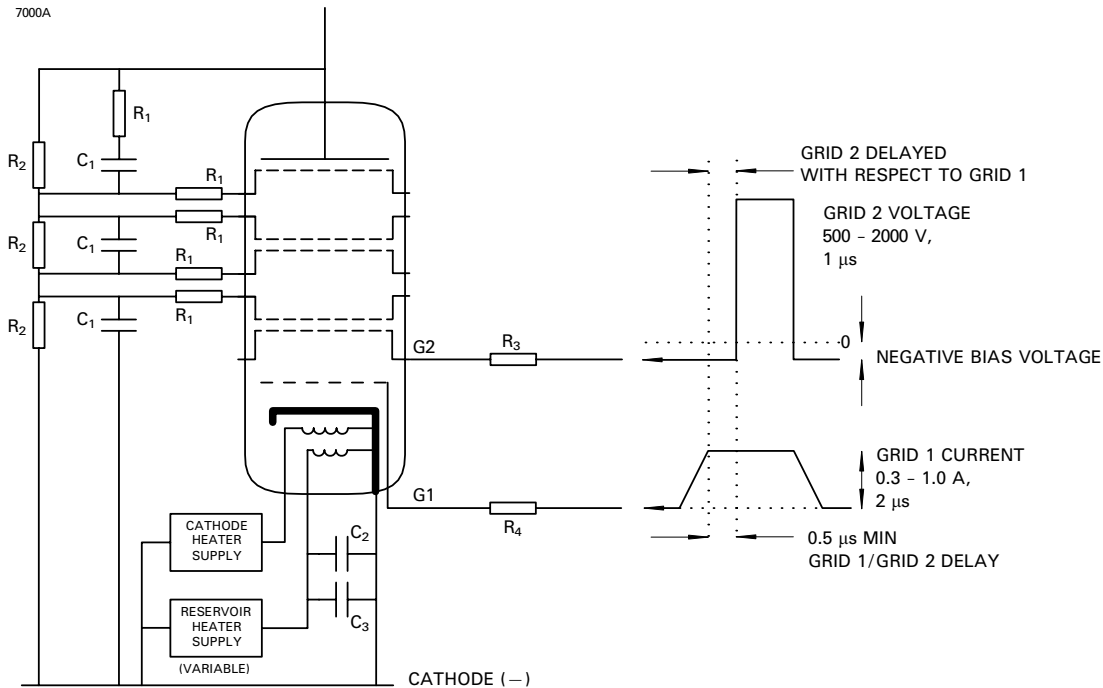

## RECOMMENDED GRADIENT GRID, TRIGGER GRID, CATHODE AND RESERVOIR HEATER CONNECTIONS

- $R_1$  = 470  $\Omega$  2.5 W vitreous enamelled wirewound resistors.
- $R_2$  = 5 to 20 M $\Omega$  high voltage resistors with a power rating consistent with forward anode voltage.
- $R_3$  = Grid 2 series resistor. 12 W vitreous enamelled wirewound is recommended, of an impedance to match the grid 2 drive pulse circuit.
- $R_4$  = Grid 1 series resistor. 12 W vitreous enamelled wirewound is recommended, of an impedance to match the grid 1 drive pulse circuit.
- $C_1$  = 300 to 500 pF capacitors with a voltage rating equal to the peak forward voltage. These capacitors may be needed to correctly divide the voltage across each gap when charging times are less than 5 ms approx.
- $C_2, C_3$  = Reservoir protection capacitors with a voltage rating  $\geq 500$  V;
- $C_2$  = 1000 pF low inductance (e.g. ceramic),
- $C_3$  = 1  $\mu$ F (e.g. polycarbonate or polypropylene).

Components  $R_3, R_4, C_2,$  and  $C_3$  should be mounted as close to the tube as possible.

## SCHEMATIC DIAGRAM (Crowbar Service)

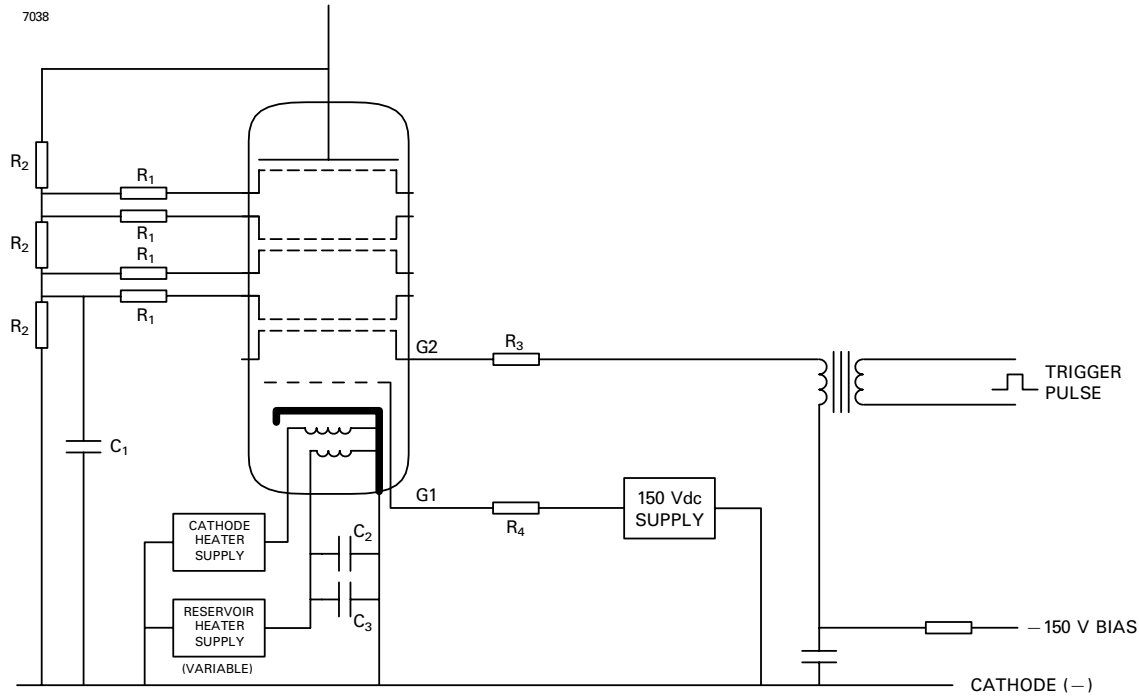

- $R_1$  = 470  $\Omega$  12 W vitreous enamelled wirewound resistors.
  - $R_2$  = 10 to 25 M $\Omega$  high voltage resistors with a power rating consistent with forward anode voltage.
  - $R_3$  = Grid 2 series resistor. 12 W vitreous enamelled wirewound is recommended, of an impedance to match the grid 2 drive pulse circuit.
  - $R_4$  = Grid 1 series resistor. 12 W vitreous enamelled wirewound is recommended.
  - $C_1$  = 500 to 1000 pF capacitor with a voltage rating equal to the peak forward voltage.
  - $C_2, C_3$  = Reservoir protection capacitors with a voltage rating  $\geq 500$  V;
    - $C_2$  = 1000 pF low inductance (e.g. ceramic),
    - $C_3$  = 1  $\mu$ F (e.g. polycarbonate or polypropylene).
- Components  $R_3, R_4, C_2,$  and  $C_3$  should be mounted as close to the tube as possible.

# OUTLINE

(All dimensions without limits are nominal)

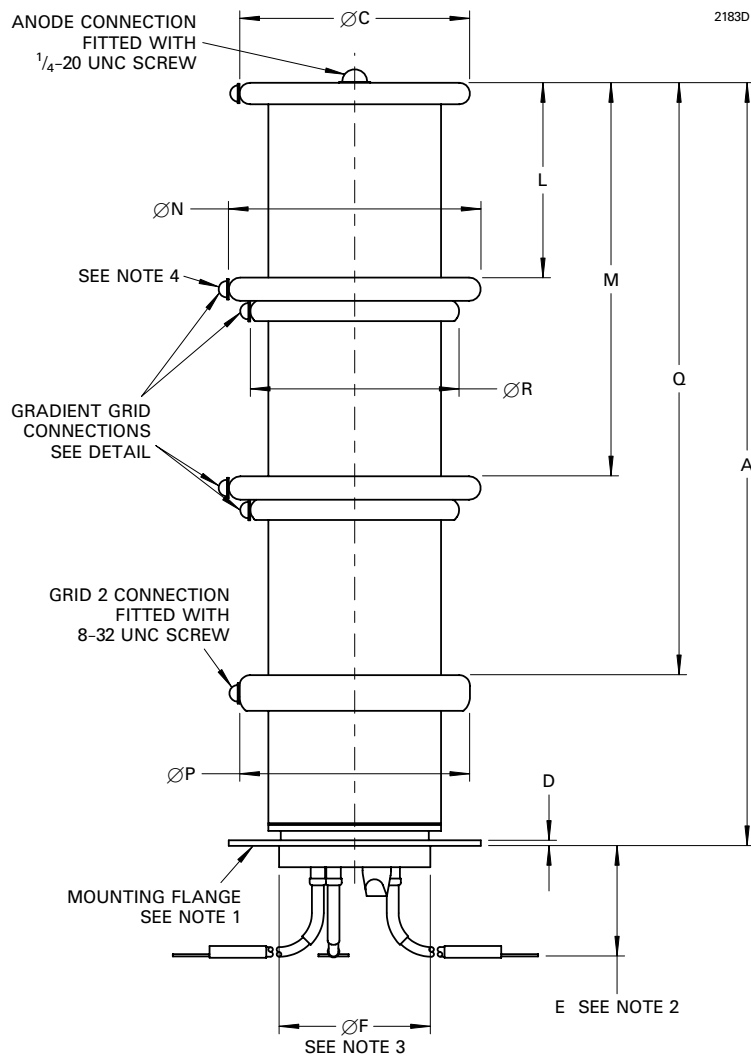

Ref	Millimetres	Inches
A	342.9 max	13.500 max
B	111.1	4.375
C	101.6	4.000
D	2.54	0.100
E	38.1 min	1.500 min
F	69.85 max	2.750 max
G	190.5 min	7.500 min
H	6.35	0.250
J	6.5	0.256
K	95.25	3.750
L	85.73	3.375
M	171.5	6.750
N	111.1	4.375
P	101.6	4.000
Q	257.2	10.125
R	92.08	3.625

Inch dimensions have been derived from millimetres.

## Outline Notes

1. The mounting flange is the connection for the cathode, cathode heater return and reservoir heater return.
2. A minimum clearance of 38.1 mm (1.500 inches) must be allowed below the mounting flange.
3. The recommended mounting hole is 73.0 mm (2.875 inches) diameter.
4. The holes for all grid connections will be in line with the hole in the mounting flange to within 10° either side of the hole centre.

## Detail of Gradient Grid Connections

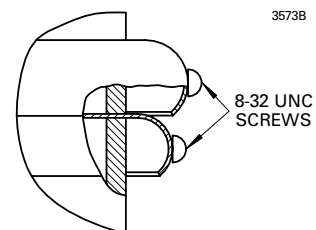

## HEALTH AND SAFETY HAZARDS

E2V Technologies hydrogen thyratrons are safe to handle and operate, provided that the relevant precautions stated herein are observed. E2V Technologies does not accept responsibility for damage or injury resulting from the use of electronic devices it produces. Equipment manufacturers and users must ensure that adequate precautions are taken. Appropriate warning labels and notices must be provided on equipments incorporating E2V Technologies devices and in operating manuals.



### High Voltage

Equipment must be designed so that personnel cannot come into contact with high voltage circuits. All high voltage circuits and terminals must be enclosed and fail-safe interlock switches must be fitted to disconnect the primary power supply and discharge all high voltage capacitors and other stored charges before allowing access. Interlock switches must not be bypassed to allow operation with access doors open.



### X-Ray Radiation

All high voltage devices produce X-rays during operation and may require shielding. The X-ray radiation from hydrogen thyratrons is usually reduced to a safe level by enclosing the equipment or shielding the thyatron with at least 1.6 mm ( $\frac{1}{16}$  inch) thick steel panels.

Users and equipment manufacturers must check the radiation level under their maximum operating conditions.

Whilst E2V Technologies has taken care to ensure the accuracy of the information contained herein it accepts no responsibility for the consequences of any use thereof and also reserves the right to change the specification of goods without notice. E2V Technologies accepts no liability beyond that set out in its standard conditions of sale in respect of infringement of third party patents arising from the use of tubes or other devices in accordance with information contained herein.