

The data to be read in conjunction with the Hydrogen Thyatron Preamble.

### ABRIDGED DATA

Hydrogen-filled, fast recovery, tetrode thyatron, specifically designed for operation under medical linac conditions. A reservoir operating from the cathode heater supply is incorporated.

Peak forward anode voltage . . . . .	25	kV max
Peak anode current . . . . .	1000	A max
Average anode current:		
continuous operation . . . . .	1.25	A max
intermittent operation . . . . .	2.2	A max

### GENERAL

#### Electrical

Cathode (connected internally to mid-point of heater) . . . . .	oxide coated
Heater voltage . . . . .	6.3 ± 5% V
Heater current . . . . .	22 A
Tube heating time (minimum) . . . . .	5.0 min

#### Mechanical

Overall length . . . . .	317.5 mm (12.500 inches) max
Overall diameter . . . . .	84.12 mm (3.312 inches) max
Net weight . . . . .	0.7 kg (1 1/2 pounds) approx
Mounting position (see note 1) . . . . .	any
Base . . . . .	pin spacing as B5F; metal shell with micaalex insert
Top cap (see note 2) . . . . .	BS448-CT3

CX1140L is also available with a flange base with flying leads as type CX1151L.

Cooling . . . . . natural

### PULSE MODULATOR SERVICE MAXIMUM AND MINIMUM RATINGS (Absolute values)

	Min	Max	
<b>Anode</b>			
Peak forward anode voltage (see note 3) . . . . .	-	25	kV
Peak inverse anode voltage (see note 4) . . . . .	-	25	kV
Peak anode current . . . . .	-	1000	A
Peak anode current (pulse repetition rate limited to 60 pps max) . . . . .	-	2000	A
Average anode current:			
continuous operation . . . . .	-	1.25	A
intermittent operation . . . . .	-	2.2	A
Rate of rise of anode current (see note 5) . . . . .	-	5000	A/μs

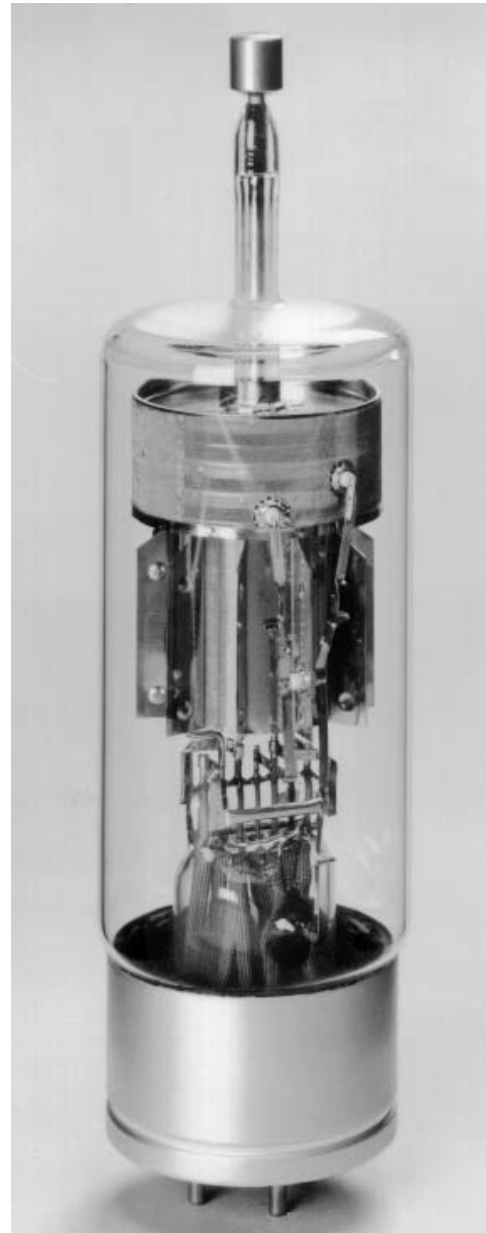

#### Grid 2

Unloaded grid 2 drive pulse voltage (see note 6) . . . . .	300	1000	V
Grid 2 pulse duration . . . . .	1.0	-	μs
Rate of rise of grid 2 pulse (see note 5) . . . . .	1.0	-	kV/μs
Grid 2 pulse delay . . . . .	0.5	3.0	μs
Peak inverse grid 2 voltage . . . . .	-	450	V
Loaded grid 2 bias voltage . . . . .	0	-150	V
Grid 2 drive impedance . . . . .	50	500	Ω
Grid 2 bias impedance . . . . .	30	50	kΩ

#### Grid 1 - DC Primed (See note 7)

DC grid 1 unloaded priming voltage . . . . .	75	150	V
DC grid 1 priming current . . . . .	50	100	mA

## MAXIMUM AND MINIMUM RATINGS (Continued)

	Min	Max	
<b>Grid 1 – Pulsed</b>			
Unloaded grid 1 drive pulse voltage (see note 6)	300	1000	V
Grid 1 pulse duration	2.0	-	μs
Rate of rise of grid 1 pulse (see note 5)	1.0	-	kV/μs
Peak inverse grid 1 voltage	-	450	V
Loaded grid 1 bias voltage	see note 8		
Peak grid 1 drive current	0.3	1.0	A

### Cathode

Heater voltage	6.3 ± 5%	V
Tube heating time	5.0	min

### Environmental

Ambient temperature	-50	+90	°C
Altitude	-	3	km
	-	10 000	ft

## CHARACTERISTICS

	Min	Typical	Max	
Critical DC anode voltage for conduction (see note 9)	-	0.5	2.0	kV
Anode delay time (see notes 9 and 10)	-	0.15	0.25	μs
Anode delay time drift (see notes 9 and 11)	-	20	50	ns
Time jitter (see note 9)	-	1.0	5.0	ns
Recovery time	see note 12 and graph, page 3			
Heater current (at 6.3 V)	18	22	25	A

## RATINGS FOR FAULT CONDITIONS, SINGLE-SHOT OR CROWBAR SERVICE (See note 7)

DC forward anode voltage	25	kV max
Peak anode current	10 000	A max
Product of peak current and pulse duration	0.6	A.s max
Repetition frequency	1 pulse per 10 s	max

## NOTES

- Clamping is only permissible by the base.
- A large area anode connector, e2v technologies type MA360, is recommended.
- The maximum permissible peak forward voltage for instantaneous starting is 25 kV and there must be no overshoot.
- The peak inverse voltage must not exceed 10 kV for the first 25 μs after the anode pulse.
- This rate of rise refers to that part of the leading edge of the pulse between 25% and 75% of the pulse amplitude.
- Measured with respect to cathode. In certain cases the maximum drive pulse voltage may be exceeded without damage to the tube; a maximum value of 2.5 kV is then recommended. When grid 1 is pulse driven, the last 0.25 μs of the top of the grid 1 pulse must overlap the corresponding first 0.25 μs of the top of the delayed grid 2 pulse.
- DC priming is recommended for crowbar service.
- DC negative bias voltages must not be applied to grid 1. When grid 1 is pulse driven, the potential of grid 1 may vary between -10 and +5 V with respect to cathode potential during the period between the completion of recovery and the commencement of the succeeding grid pulse.
- Typical figures are obtained on test using conditions of minimum grid drive. Improved performance can be expected by increasing the grid drive.
- The time interval between the instant at which the rising unloaded grid 2 pulse reaches 25% of its pulse amplitude and the instant when anode conduction takes place.
- The drift in delay time over a period from 10 seconds to 10 minutes after reaching full voltage.
- The recovery characteristics are controlled on a sampling basis.

## MA91 ADAPTOR ASSEMBLY

In addition to standard top cap connectors and base sockets, adaptor assembly MA91 is available from e2v technologies. This is a five-contact socket fitted with flexible leads and terminal tags, and mounted on an insulating base plate. It provides a conversion from base to flange type mounting.

CX1140L is also available with a flange base with flying leads as type CX1151L.

**Further information is contained in the leaflet 'Accessories for Hydrogen Thyratrons'.**

## HEALTH AND SAFETY HAZARDS

e2v technologies hydrogen thyratrons are safe to handle and operate, provided that the relevant precautions stated herein are observed. e2v technologies does not accept responsibility for damage or injury resulting from the use of electronic devices it produces. Equipment manufacturers and users must ensure that adequate precautions are taken. Appropriate warning labels and notices must be provided on equipments incorporating e2v technologies devices and in operating manuals.



### High Voltage

Equipment must be designed so that personnel cannot come into contact with high voltage circuits. All high voltage circuits and terminals must be enclosed and fail-safe interlock switches must be fitted to disconnect the primary power supply and discharge all high voltage capacitors and other stored charges before allowing access. Interlock switches must not be bypassed to allow operation with access doors open.



### X-Ray Radiation

All high voltage devices produce X-rays during operation and may require shielding. The X-ray radiation from hydrogen thyratrons is usually reduced to a safe level by enclosing the equipment or shielding the thyratron with at least 1.6 mm ( $1/16$  inch) thick steel panels.

Users and equipment manufacturers must check the radiation level under their maximum operating conditions.

## MAXIMUM RECOVERY CHARACTERISTICS

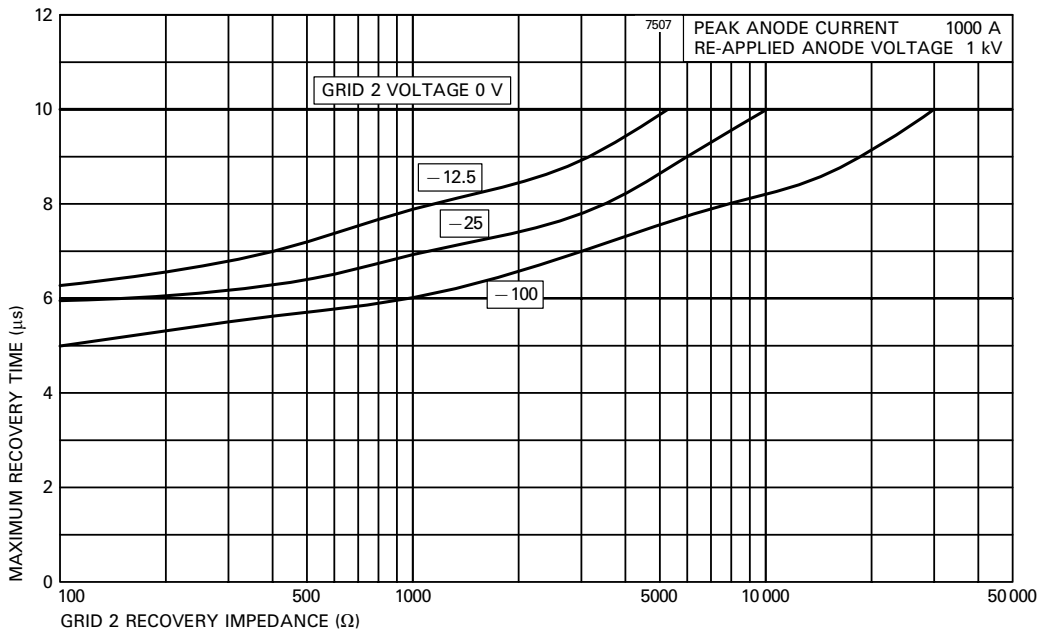

# OUTLINE

(All dimensions without limits are nominal)

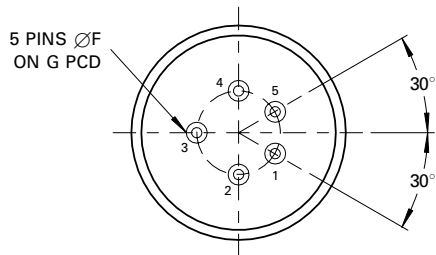
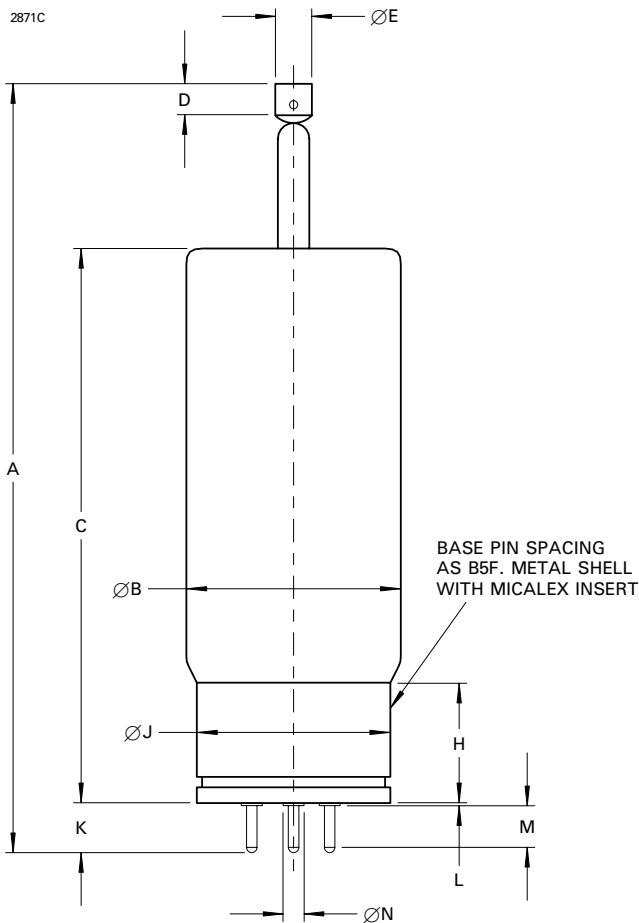

Ref	Millimetres	Inches
A	304.8 ± 12.7	12.000 ± 0.500
B	84.12 max	3.312 max
C	215.9 ± 12.7	8.500 ± 0.500
D	12.7 min	0.500 min
E	14.38 ± 0.18	0.566 ± 0.007
F	4.750 ± 0.076	0.187 ± 0.003
G	31.75	1.250
H	49.2	1.937
J	77.77 ± 1.57	3.062 ± 0.062
K	19.56 max	0.770 max
L	1.85 max	0.073 max
M	14.6 min	0.575 min
N	6.6 max	0.260 max

Inch dimensions have been derived from millimetres.

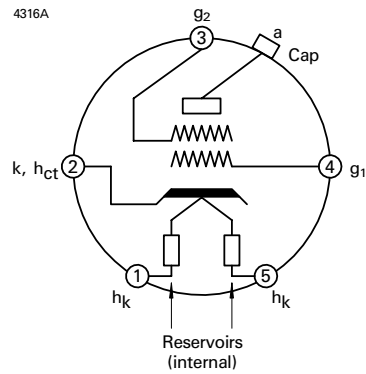

Pin	Element
1	Heater
2	Cathode, connected internally to heater mid-point
3	Grid 2
4	Grid 1
5	Heater
Top cap	Anode

Whilst e2v technologies has taken care to ensure the accuracy of the information contained herein it accepts no responsibility for the consequences of any use thereof and also reserves the right to change the specification of goods without notice. e2v technologies accepts no liability beyond that set out in its standard conditions of sale in respect of infringement of third party patents arising from the use of tubes or other devices in accordance with information contained herein.