

TC5561P/J-45,-55,-70

65,536 WORD x 1 BIT CMOS STATIC RAM

DESCRIPTION

The TC5561P/J is a 65,536 bit high speed static random access memory organized as 65,536 words by 1 bit using CMOS technology, and operated from a single 5-volt supply. Toshiba's high performance device technology provides both high speed and low power features with a maximum access time of 45ns/55ns/70ns and maximum operating current of 100mA at minimum cycle time. The TC5561P/J also features an automatic stand-by mode. When deselected by Chip Enable (\overline{CE}), the operating current is reduced from 100mA to 2mA. The TC5561P/J is suitable for use in main memory of high speed computer and pattern memory, where high speed/low power/high density are required. The TC5561P is moulded in a 22 pin plastic DIP with 300 mil width for high density assembly and the TC5561J is moulded in a 24 pin plastic SOJ with 300 mil width for high density surface assembly. The TC5561P/J is fabricated with ion implanted CMOS silicon gate MOS technology for high performance and high reliability.

FEATURES

- Fast access time: TC5561P/J-45 45ns(MAX.)
TC5561P/J-55 55ns(MAX.)
TC5561P/J-70 70ns(MAX.)
- Low power dissipation: Operation 100mA(MAX.)
Standby 2mA(MAX.)
- 5V single power supply
- Fully static operation
- Directly TTL compatible:
All Input and Output
- I/O separate
- Package: 22 Pin plastic 300 mil DIP : TC5561P
24 Pin plastic 300 mil SOJ : TC5561J

PIN CONNECTION

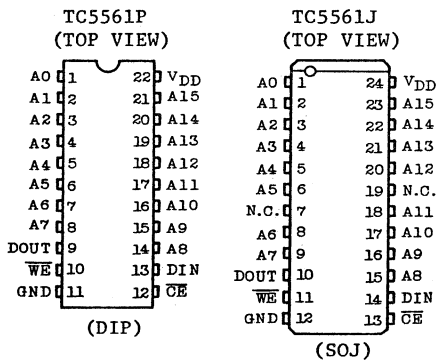

PIN NAMES

A0 ~ A15	Address Inputs
DIN	Data Input
DOUT	Data Output
\overline{CE}	Chip Enable Input
\overline{WE}	Write Enable Input
VDD	Power (+5V)
GND	Ground
N.C.	No Connection

BLOCK DIAGRAM

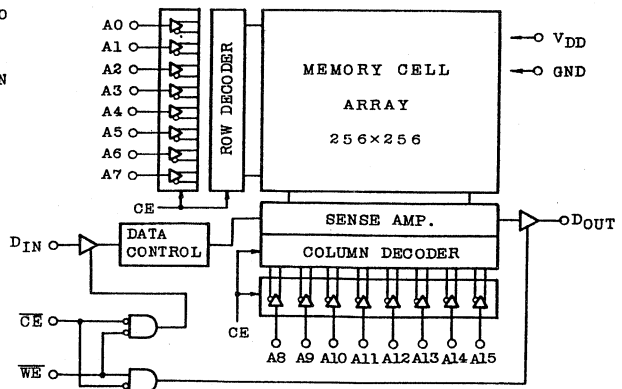

TC5561P/J-45,-55,-70

MAXIMUM RATINGS

SYMBOL	ITEM	RATING	UNIT
V _{DD}	Power Supply Voltage	-0.3 ~ 7.0	V
V _{IN}	Input Voltage	-2.0 ~ 7.0	V
V _{OUT}	Output Voltage	-0.5 ~ V _{DD} +0.5	V
P _D	Power Dissipation	650	mW
T _{solder}	Soldering Temperature	260 . 10	°C . sec
T _{stg}	Storage Temperature	-65 ~ 150	°C
T _{opr}	Operating Temperature	0 ~ 70	°C

D.C. RECOMMENDED OPERATING CONDITIONS

SYMBOL	PARAMETER	MIN.	TYP.	MAX.	UNIT
V _{DD}	Power Supply Voltage	4.5	5.0	5.5	V
V _{IH}	Input High Voltage	2.2	-	V _{DD} +0.3	V
V _{IL}	Input Low Voltage	-0.3	-	0.8	V
V _{DH}	Data Retention Supply Voltage	2.0	-	5.5	V

D.C. and OPERATING CHARACTERISTICS (Ta=0 ~ 70°C, V_{DD}=5V±10%)

SYMBOL	PARAMETER	TEST CONDITION	MIN.	TYP.	MAX.	UNIT
I _{IL}	Input Leakage Current	V _{IN} =0 ~ V _{DD}	-	-	±1.0	μA
I _{OH}	Output High Current	V _{OH} =2.4V	-8	-	-	mA
I _{OL}	Output Low Current	V _{OL} =0.4V	8	-	-	mA
I _{LO}	Output Leakage Current	$\overline{CE}=V_{IH}$ or $\overline{WE}=V_{IL}$ V _{OUT} =0 ~ V _{DD}	-	-	±1.0	μA
I _{DDO}	Operating Current	V _{DD} =5.5V, t _{cyc} I _e =Min cycle $\overline{CE}=V_{IL}$ Other Input=V _{IH} /V _{IL}	-	-	100	mA
I _{DDS1}	Standby Current	$\overline{CE}=V_{IH}$	-	-	2	mA
I _{DDS2}		$\overline{CE}=V_{DD}-0.2V$	-	-	100	μA

CAPACITANCE (Ta=25°C)

SYMBOL	PARAMETER	TEST CONDITION	MAX.	UNIT
C _{IN}	Input Capacitance	V _{IN} =GND	10	pF
C _{OUT}	Output Capacitance	V _{OUT} =GND	10	pF

Note: This parameter periodically sampled is not 100% tested.

A.C. CHARACTERISTICS ($T_a=0 \sim 70^\circ\text{C}$, $V_{DD}=5\text{V}\pm 10\%$)

Read cycle

SYMBOL	PARAMETER	TC5561P-45 TC5561J-45		TC5561P-55 TC5561J-55		TC5561P-70 TC5561J-70		UNIT
		MIN.	MAX.	MIN.	MAX.	MIN.	MAX.	
t_{RC}	Read Cycle Time	45	-	55	-	70	-	ns
t_{ACC}	Address Access Time	-	45	-	55	-	70	ns
t_{CO}	Chip Enable Access Time	-	45	-	55	-	70	ns
t_{COE}	Chip Enable to Output in Low-Z	5	-	5	-	5	-	ns
t_{COD}	Chip Enable to Output in High-Z	-	15	-	15	-	15	ns
t_{OH}	Output Data Hold Time	5	-	5	-	5	-	ns

Write cycle

SYMBOL	PARAMETER	TC5561P-45 TC5561J-45		TC5561P-55 TC5561J-55		TC5561P-70 TC5561J-70		UNIT
		MIN.	MAX.	MIN.	MAX.	MIN.	MAX.	
t_{WC}	Write Cycle Time	45	-	55	-	70	-	ns
t_{WP}	Write Pulse Width	30	-	35	-	35	-	ns
t_{CW}	Chip Enable to End of Write	30	-	35	-	35	-	ns
t_{AW}	Address Set up Time	0	-	0	-	0	-	ns
t_{WR}	Write Recovery Time	0	-	0	-	0	-	ns
t_{ODW}	\overline{WE} to Output High-Z	-	15	-	15	-	15	ns
t_{OEW}	\overline{WE} to Output Low-Z	0	-	0	-	0	-	ns
t_{DS}	Data Set up Time	25	-	25	-	30	-	ns
t_{DH}	Data Hold Time	0	-	0	-	0	-	ns

A.C. TEST CONDITIONS

Input Pulse Levels	0.6V, 2.4V
Input Rise and Fall Time	5ns
Input and Output Timing Reference Levels	1.5V
Output Load	See Fig. 1

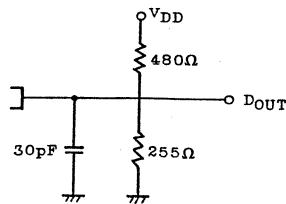
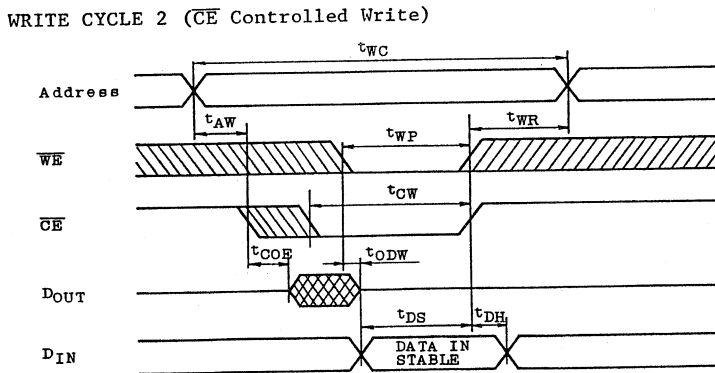
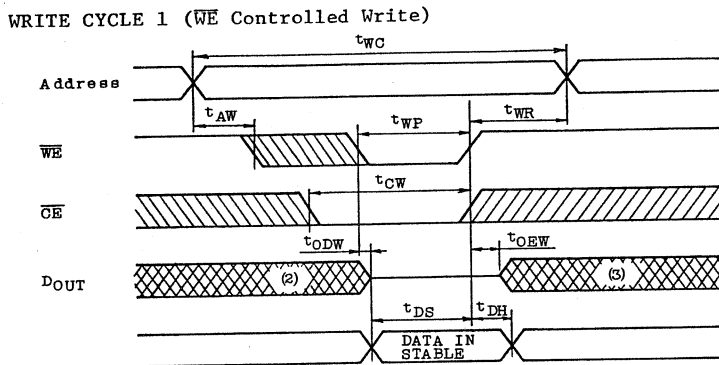
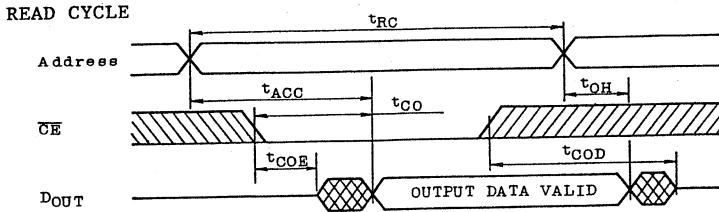

Fig.1 Output Load

TIMING WAVEFORMS



- Note: 1. R/W is High for Read Cycle.
 2. Assuming that \overline{CE} Low transition occurs coincidentally or after \overline{WE} Low transition, outputs remain in a high impedance state.
 3. Assuming that \overline{CE} High transition occurs coincidentally or prior to \overline{WE} High transition, outputs remain in a high impedance state.
 4. The operating temperature (T_a) is guaranteed with transverse air flow exceeding 400 linear feet per minute.

DATA RETENTION CHARACTERISTICS (Ta=0 ~ 70°C)

SYMBOL	PARAMETER	MIN.	TYP.	MAX.	UNIT	
V _{DH}	Data Retention Supply Voltage	2.0	-	5.5	V	
I _{DDS2}	Standby Supply Current	V _{DD} =3.0V	-	-	50	μA
		V _{DD} =5.5V	-	-	100	
t _{CDR}	Chip Deselection to Data Retention Mode	0	-	-	ns	
t _R	Recovery Time	TC5561P-45	45	-	-	ns
		TC5561P-55	55	-	-	
		TC5561P-70	70	-	-	

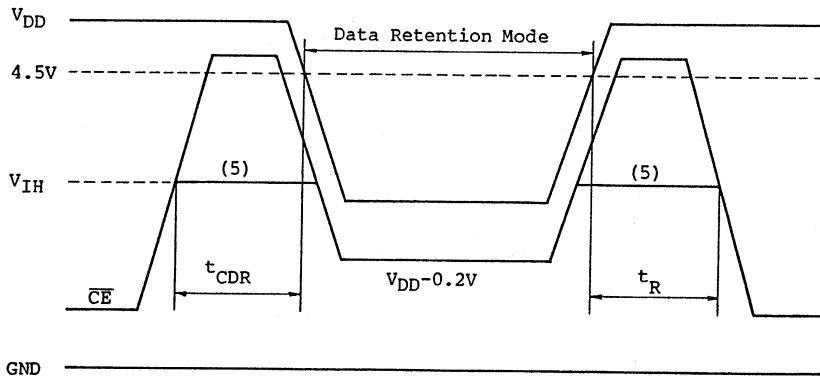

Note: 5. If the V_{IH} of CE is 2.2V in operation, I_{DDS1} current flows during the period that the V_{DD} voltage is going down from 4.5V to 2.4V.

TOSHIBA

DATA BOOK

MOS MEMORY
(VRAM, SRAM)

1991

INTRODUCTION

We continually venture at the leading edge of technology so that we may develop and offer to you a diverse array of semiconductor memory products which may be used in many commercial and industrial applications. At this time, we offer three data books; "MOS-Memory Dynamic RAM and Module", "MOS-Memory Video RAM and Static RAM" and "MOS-Memory ROM".

Particularly, this data book is "MOS-Memory Video RAM and Static RAM" edition.

These data books represent our current culminations of electrical characteristics, timing waveforms and package data for our line of semiconductor memory products.

We hope this information will be very useful for you.

Nov. 1991

TOSHIBA CORPORATION
Semiconductor Group

Unit in mm

DIP22-P-300

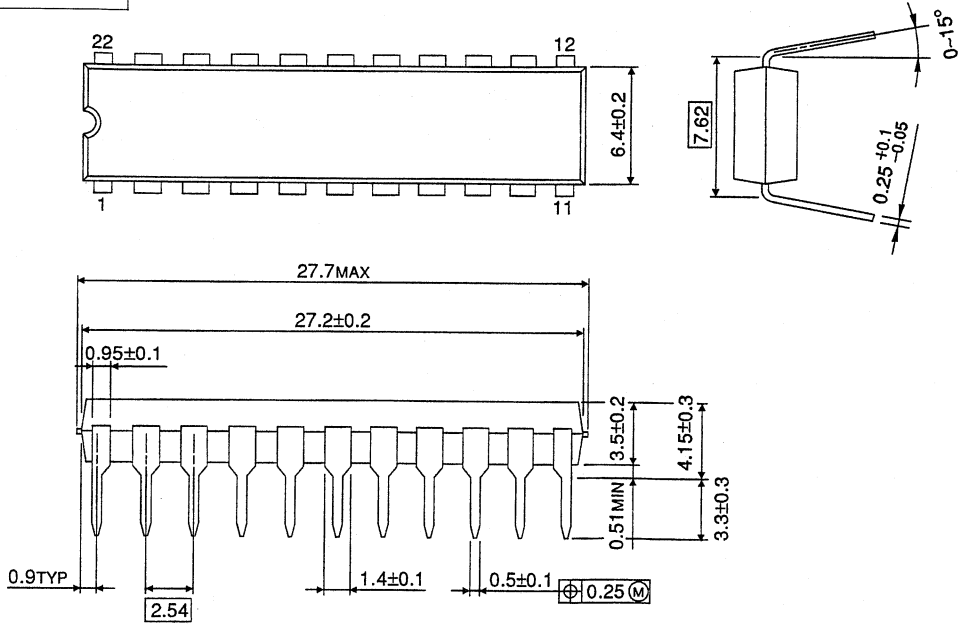

DIP24-P-300B

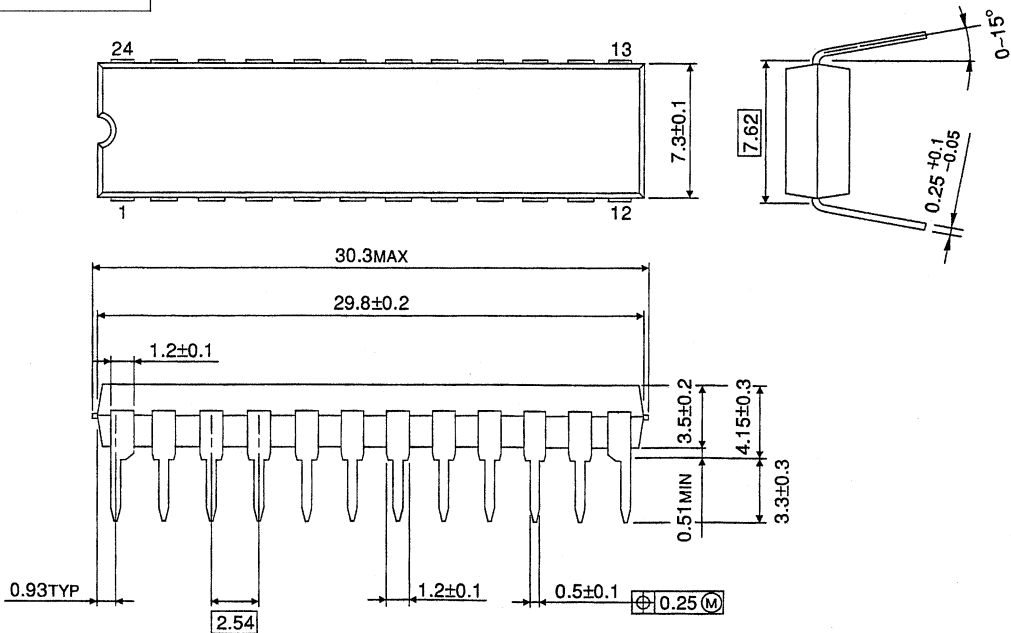

SOJ24-P-300

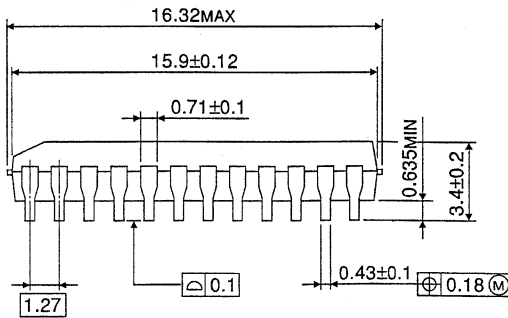
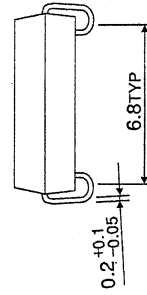
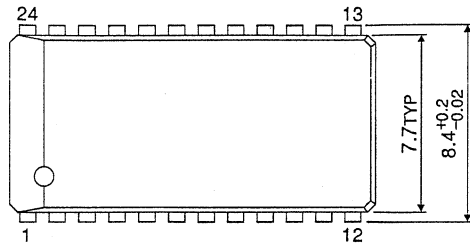

SOJ24-P-300A

