

# SVETLANA TECHNICAL DATA

## 3CW30,000H3

### Medium-Mu Industrial Triode



**T**he Svetlana™ 3CW30,000H3 is a high-performance ceramic/metal, water-cooled power triode designed primarily for use in industrial RF applications as an oscillator. A modern mesh filament is used. The improved mesh filament design ensures better mechanical rigidity and long lasting concentricity of the filament providing reduced warm-up variation and longer life. The low-inductance, mesh-filament basket also forms a natural extension of the cylindrical stem geometry into the active area, giving superior VHF performance to 90MHz.

The Svetlana 3CW30,000H3 is manufactured in the Svetlana Electron Devices complex in St. Petersburg, Russia. Svetlana has achieved the improved performance described above with exact replacement compatibility with the 3CW30,000H3 manufactured in the United States.

#### Characteristics

##### Electrical

Filament	Thoriated-tungsten mesh	
Voltage	6.3 ± 0.3	V
Current @ 6.3V	160	A
Amplification factor	20	
Direct interelectrode capacitances (grounded cathode)		
Input	53.0	pF
Output	1.3	pF
Feedback	34.0	pF
Maximum frequency for full ratings	90	MHz

##### Mechanical

Cooling	Water and forced air	
Base	Flying leads/flange	
Operating position	Vertical, Base up or down	
Maximum operating temperature	250°	C
Maximum dimensions:		
Length	302.7 mm (11.92 in.)	
Diameter	171.5 mm (6.75 in.)	
Net Weight	5.45 kg (12 lb)	

##### Class C RF Oscillator

Maximum Ratings		
DC plate voltage	12,000	V
DC plate current	6.0	A
Grid voltage	-1000	V
Grid current	1.0	A
Plate dissipation	30	kW
Plate input power	60	kW

#### Svetlana Outline drawing

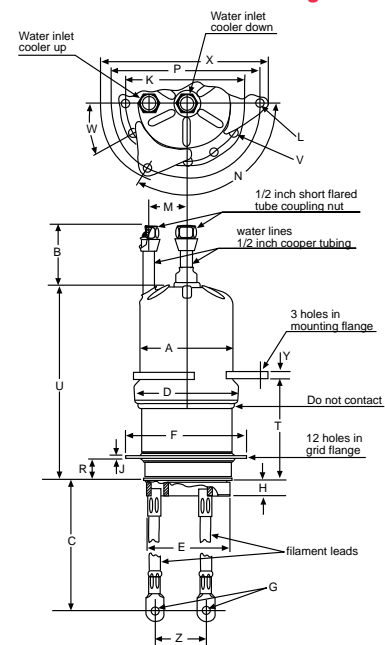

	Millimeters			Inches		
	Min.	Max.	Ref.	Min.	Max.	Ref.
A	103.99	105.56	—	4.094	4.156	—
B	56.72	71.42	—	2.312	2.812	—
C	215.90	228.60	—	8.500	9.000	—
D	116.69	119.40	—	4.594	4.700	—
E	82.04	83.06	—	3.230	3.270	—
F	127.76	129.29	—	5.030	5.090	—
G	—	—	9.91	—	—	.390
H	13.46	17.8	—	.530	.7	—
J	—	—	3.18	—	—	.125
K	112.40	112.90	—	4.425	4.445	—
L	—	6.73	—	—	—	.265
M	38.10	44.45	—	1.500	1.750	—
N	118°	112°	—	118°	122°	—
P	151.31	153.04	—	5.957	6.025	—
R	17.78	21.84	—	.700	.860	—
T	110.49	113.03	—	4.350	4.450	—
U	200.74	213.44	—	7.903	8.403	—
V	—	—	6.35	—	—	.250
W	29°	31°	—	29°	31°	—
X	—	—	171.45	—	—	6.750
Y	—	—	6.35	—	—	.250
Z	—	—	50.80	—	—	2.000



**Svetlana**  
ELECTRON DEVICES

**Headquarters:**  
8200 South Memorial Parkway  
Huntsville, AL 35802  
USA  
Phone: 205 882 1344  
Fax: 205 880 8077

**Marketing & Engineering:**  
3000 Alpine Road  
Portola Valley, CA 94028  
USA  
Phone: 415 233 0429  
Fax: 415 233 0439

[www.svetlana.com](http://www.svetlana.com)

# Svetlana 3CW30,000H3 Medium-Mu Industrial Triode



**Svetlana**  
ELECTRON DEVICES

Typical Operation (Filtered DC Power)

DC plate voltage	10,000	7000	V
DC grid voltage	-800	-600	V
DC plate current	6.0	6.0	A
DC grid current*	0.315	0.66	A
Peak RF grid voltage*	360	440	V
Driving power	365	660	W
Plate output power	42	30	kW
Plate dissipation	18	12	kW
Load impedance*	750	600	ohms

\*Approximate values

## Minimum Cooling Water-Flow Requirements

Plate dissipation (kW)	Water flow (gpm)	Pressure drop (approx. psi.)
15	12	13.5
20	13	15.0
30	14	17.0

NOTES:

1. Maximum system pressure is 50 PSIG
2. 50 CFM of forced air cooling must be directed onto the base and filament areas.

