

The data to be read in conjunction with the Hydrogen Thyatron Preamble.

### ABRIDGED DATA

Hydrogen-filled tetrode thyatron, featuring low jitter and low anode delay time drift. Suitable for use at high pulse repetition rates, in parallel for switching higher powers, or for switching long pulses. A reservoir operating from the cathode heater supply is incorporated. The CX1140 replaces many less sophisticated thyatrons of similar rating when used with base adaptors obtainable from e2v technologies. Details of these adaptors are given on page 2.

Peak forward anode voltage . . . . .	25	kV max
Peak anode current . . . . .	1000	A max
Average anode current . . . . .	1.25	A max
Anode heating factor . . . . .	$9.0 \times 10^9$	VApps max
Peak output power . . . . .	12.5	MW max

### GENERAL

#### Electrical

Cathode (connected internally to mid-point of heater) . . . . .	oxide coated
Heater voltage . . . . .	$6.3 \pm 5\%$ V
Heater current . . . . .	22 A
Tube heating time (minimum) . . . . .	5.0 min
Inter-electrode capacitances (approximate):	
anode to grid 2 (grid 1 and cathode not connected) . . . . .	13 pF
anode to grid 1 (grid 2 and cathode not connected) . . . . .	7.5 pF
anode to cathode (grid 1 and grid 2 not connected) . . . . .	26 pF

#### Mechanical

Overall length . . . . .	317.5 mm (12.500 inches) max
Overall diameter . . . . .	84.12 mm (3.312 inches) max
Net weight . . . . .	0.7 kg (1 1/2 pounds) approx
Mounting position (see note 1) . . . . .	any
Base . . . . .	pin spacing as B5F; metal shell with micalex insert
Top cap (see note 2) . . . . .	BS448-CT3

CX1140 is also available with a flange base with flying leads as type CX1151.

Cooling . . . . .	natural
-------------------	---------



**PULSE MODULATOR SERVICE  
MAXIMUM AND MINIMUM RATINGS  
(Absolute values)**

	Min	Max	
<b>Anode</b>			
Peak forward anode voltage (see note 3)	-	25	kV
Peak inverse anode voltage (see note 4)	-	25	kV
Peak anode current	-	1000	A
Peak anode current (pulse repetition rate limited to 60 pps max)	-	2000	A
Average anode current	-	1.25	A
Rate of rise of anode current (see note 5)	-	5000	A/μs
Anode heating factor	-	9.0 x 10 <sup>9</sup>	VApps

**Grid 2**

Unloaded grid 2 drive pulse voltage (see note 6)	200	1000	V
Grid 2 pulse duration	1.0	-	μs
Rate of rise of grid 2 pulse (see note 5)	1.0	-	kV/μs
Grid 2 pulse delay	0.5	3.0	μs
Peak inverse grid 2 voltage	-	450	V
Loaded grid 2 bias voltage	-50	-150	V
Forward impedance of grid 2 drive circuit	50	800	Ω

**Grid 1 – DC Primed (See note 7)**

DC grid 1 unloaded priming voltage	75	150	V
DC grid 1 priming current	50	100	mA

**Grid 1 – Pulsed**

Unloaded grid 1 drive pulse voltage (see note 6)	300	1000	V
Grid 1 pulse duration	2.0	-	μs
Rate of rise of grid 1 pulse (see note 5)	1.0	-	kV/μs
Peak inverse grid 1 voltage	-	450	V
Loaded grid 1 bias voltage	-	-	see note 8
Peak grid 1 drive current	0.3	1.0	A

**Cathode**

Heater voltage	6.3 ± 5%	-	V
Tube heating time	5.0	-	min

**Environmental**

Ambient temperature	-50	+90	°C
Altitude	-	3	km
	-	10 000	ft

**CHARACTERISTICS**

	Min	Typical	Max	
Critical DC anode voltage for conduction (see note 9)	-	0.5	2.0	kV
Anode delay time (see notes 9 and 10)	-	0.15	0.25	μs
Anode delay time drift (see notes 9, 11 and 12)	-	20	50	ns
Time jitter (see notes 9 and 12)	-	1.0	5.0	ns
Recovery time	-	-	-	see note 13 and curves
Heater current (at 6.3 V)	18	22	25	A

**RATINGS FOR SINGLE-SHOT OR  
CROWBAR SERVICE (See note 7)**

DC forward anode voltage	25	-	kV max
Peak anode current	15 000	-	A max
Product of peak current and pulse duration	0.6	-	A.s max
Repetition frequency	1 pulse per 10s	-	max

**NOTES**

- Clamping is only permissible by the base.
- A large area anode connector, e2v technologies type MA360, is recommended.
- The maximum permissible peak forward voltage for instantaneous starting is 20 kV and there must be no overshoot.
- The peak inverse voltage must not exceed 10 kV for the first 25 μs after the anode pulse.
- This rate of rise refers to that part of the leading edge of the pulse between 25% and 75% of the pulse amplitude.
- Measured with respect to cathode. In certain cases the maximum drive pulse voltage may be exceeded without damage to the tube; a maximum value of 2.5 kV is then recommended. When grid 1 is pulse driven, the last 0.25 μs of the top of the grid 1 pulse must overlap the corresponding first 0.25 μs of the top of the delayed grid 2 pulse.
- When DC priming is used on grid 1, a negative bias of 100 to 200 V must be applied to grid 2 to ensure anode voltage hold-off. DC priming is recommended for crowbar service.
- DC negative bias voltages must not be applied to grid 1. When grid 1 is pulse driven, the potential of grid 1 may vary between -10 and +5 V with respect to cathode potential during the period between the completion of recovery and the commencement of the succeeding grid pulse.
- Typical figures are obtained on test using conditions of minimum grid drive. Improved performance can be expected by increasing the grid drive.
- The time interval between the instant at which the rising unloaded grid 2 pulse reaches 25% of its pulse amplitude and the instant when anode conduction takes place.
- The drift in delay time over a period from 10 seconds to 10 minutes after reaching full voltage.
- For equipment where jitter and anode delay time drift are not important, the tube may be triggered by applying a single pulse to grid 2 and connecting grid 1 to grid 2 via a 1000 pF capacitor shunted by a 0.1 MΩ resistor. These components are incorporated in adaptor assemblies MA92 and MA179 (see below).
- The recovery characteristics are controlled on a sampling basis.

## ADAPTOR ASSEMBLIES

In addition to standard top cap connectors and base sockets, a number of adaptor assemblies are available from e2v technologies. They assist in the replacement of other types of thyratron by CX1140, as indicated below.

The CX1140 is also available with a flange base with flying leads as type CX1151.

**MA91** For replacing GHT3/CV5721

A five-contact socket fitted with flexible leads and terminal tags, and mounted on an insulating base plate. It provides a conversion from base to flange type mounting.

**MA92** For replacing 1754/5948 (CV3518)

Similar to MA91 but incorporates an RC network and is designed for use with CX1140 where a single pulse drive and flying lead connections are required. Where CX1140 and MA92 replace 1754/5948 (CV3518), it should be noted that no lead is provided for a hydrogen reservoir connection as the CX1140 does not require a separate supply.

**MA179** For replacing 1754/5948 and with tube clamping

A five-contact socket with flexible leads and terminal tags, mounted on an insulating base plate; it is fitted with a base clamp. It incorporates an RC network and is designed for use with CX1140 where a single pulse drive and flying lead connections are required.

See below for conversion of 5949/1907 or 5949A socket to use CX1140.

**Further information is contained in the leaflet 'Accessories for Hydrogen Thyratrons'.**

### Conversion of 5949/1907 or 5949A socket to use CX1140/CV8563

1) View of 5949/1907 or 5949A socket from underneath

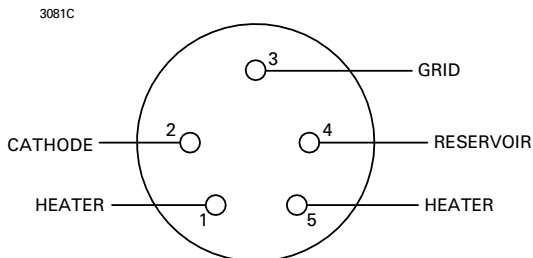

2) View of 5949/1907 or 5949A socket modified to use CX1140

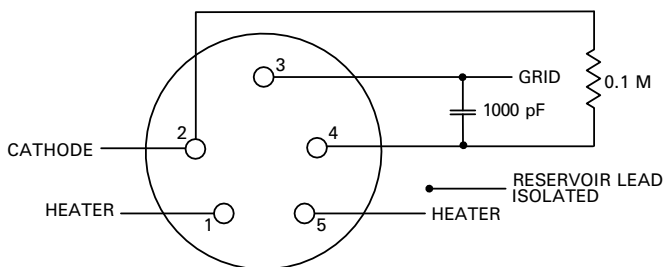

## HEALTH AND SAFETY HAZARDS

e2v technologies hydrogen thyratrons are safe to handle and operate, provided that the relevant precautions stated herein are observed. e2v technologies does not accept responsibility for damage or injury resulting from the use of electronic devices it produces. Equipment manufacturers and users must ensure that adequate precautions are taken. Appropriate warning labels and notices must be provided on equipments incorporating e2v technologies devices and in operating manuals.



### High Voltage

Equipment must be designed so that personnel cannot come into contact with high voltage circuits. All high voltage circuits and terminals must be enclosed and fail-safe interlock switches must be fitted to disconnect the primary power supply and discharge all high voltage capacitors and other stored charges before allowing access. Interlock switches must not be bypassed to allow operation with access doors open.



### X-Ray Radiation

All high voltage devices produce X-rays during operation and may require shielding. The X-ray radiation from hydrogen thyratrons is usually reduced to a safe level by enclosing the equipment or shielding the thyratron with at least 1.6 mm ( $\frac{1}{16}$  inch) thick steel panels.

Users and equipment manufacturers must check the radiation level under their maximum operating conditions.

3) Conversion Procedure

The following components are required; they should be rated to withstand the existing grid drive power.

One 0.1 M $\Omega$  resistor.

One 1000 pF mica capacitor.

a) Remove reservoir lead from pin 4 and isolate.

b) Connect the 0.1 M $\Omega$  resistor and 1000 pF capacitor as shown.

c) Plug in CX1140.

# OUTLINE

(All dimensions without limits are nominal)

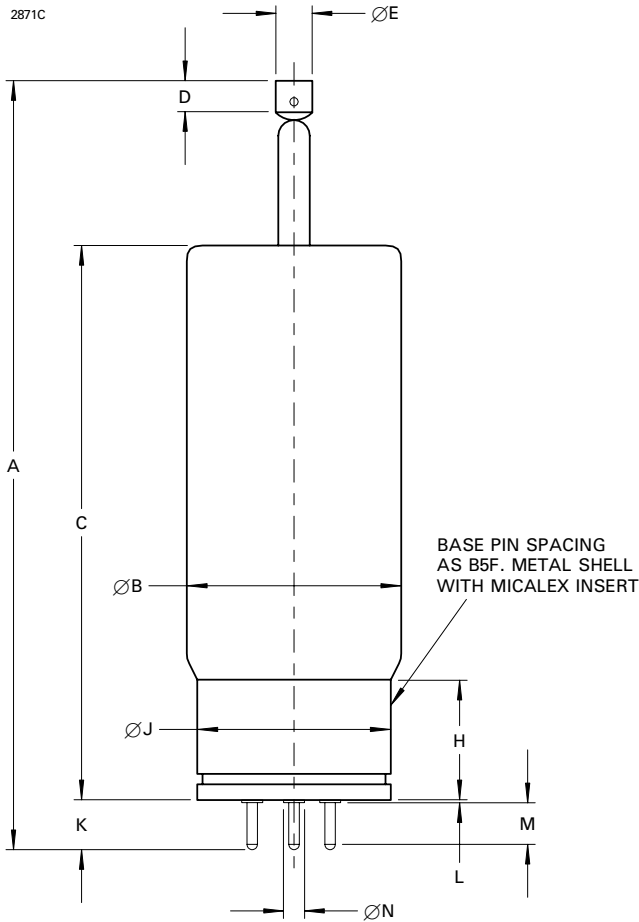

Ref	Millimetres	Inches
A	304.8 ± 12.7	12.000 ± 0.500
B	84.12 max	3.312 max
C	215.9 ± 12.7	8.500 ± 0.500
D	12.7 min	0.500 min
E	14.38 ± 0.18	0.566 ± 0.007
F	4.750 ± 0.076	0.187 ± 0.003
G	31.75	1.250
H	49.2	1.937
J	77.77 ± 1.57	3.062 ± 0.062
K	19.56 max	0.770 max
L	1.85 max	0.073 max
M	14.6 min	0.575 min
N	6.6 max	0.260 max

Inch dimensions have been derived from millimetres.

Pin	Element
1	Heater
2	Cathode, connected internally to heater mid-point
3	Grid 2
4	Grid 1
5	Heater
Top cap	Anode

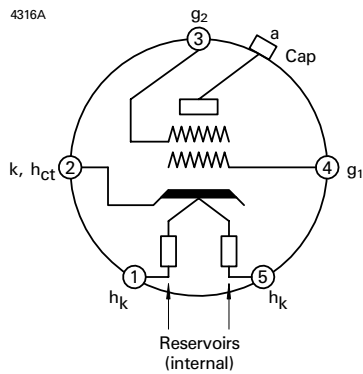
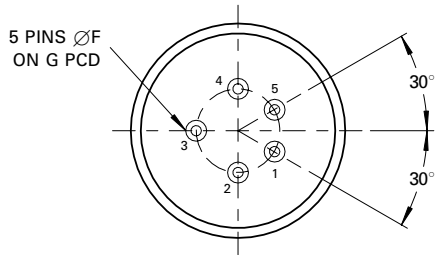

# MAXIMUM RECOVERY CHARACTERISTICS

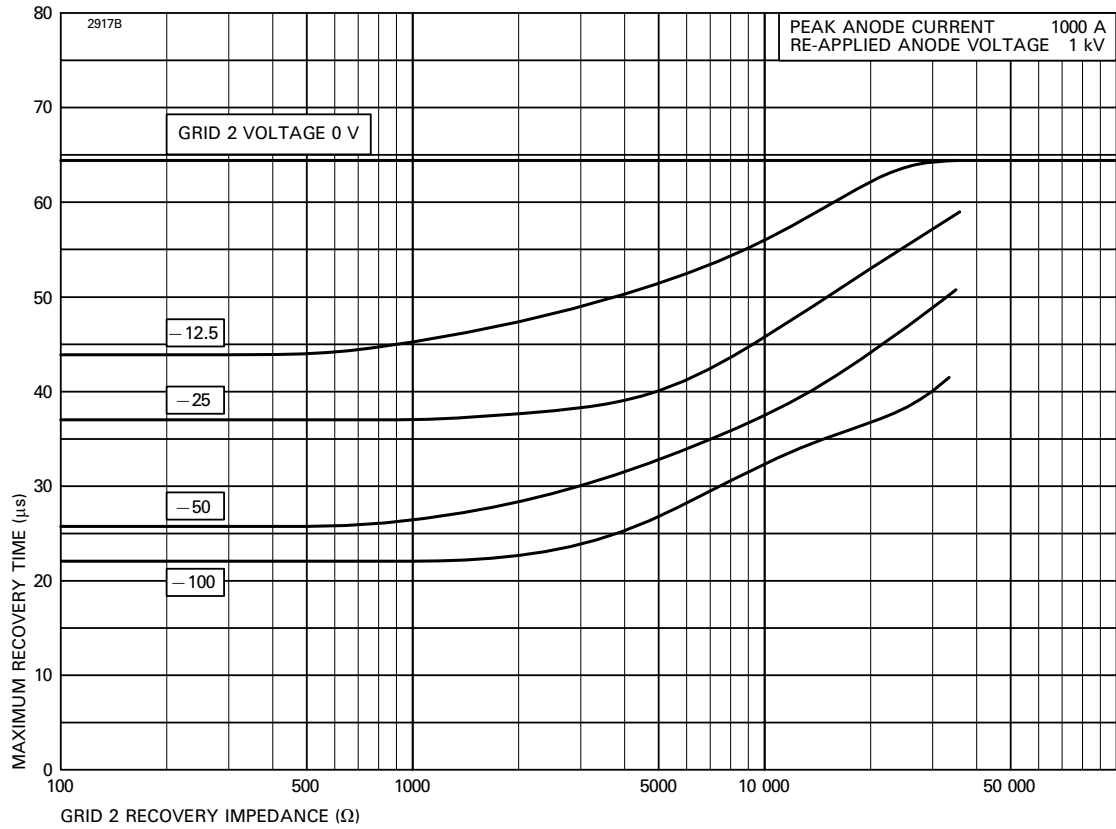

Whilst e2v technologies has taken care to ensure the accuracy of the information contained herein it accepts no responsibility for the consequences of any use thereof and also reserves the right to change the specification of goods without notice. e2v technologies accepts no liability beyond that set out in its standard conditions of sale in respect of infringement of third party patents arising from the use of tubes or other devices in accordance with information contained herein.